

TREADBRITE TEXTURE NOT SHOWN IN TOP VIEW

REFERENCE SCALE IN INCHES

COMP.	HEIGHT	WIDTH	USABLE UPPER	USABLE LOWER	DEPTH	DMIDE	HEIGHT	FT'
DFW	67.12	47.88	14	26	28	28	35.35	
DAW	37.12	63.75	14	-	-	-	19.18	
DRW	67.12	44.00	14	26	28	28	32.49	
DFW	67.12	47.88	14	26	28	28	35.35	
PAW	37.12	63.75	14	-	-	-	19.18	
PRW	67.12	44.00	14	26	28	28	32.49	
R-1	70.12	44.00	-	30	-	-	53.56	
HOSEBED	14	68	-	142	-	-	78.23	
FRONT X-LAY	25.75	4.62	-	73.75	-	-	5.08	
REAR X-LAY	25.75	4.62	-	73.75	-	-	5.08	

LOCATION TO BE DETERMINED:
 SINGLE SHELF TRACK (4 COMPARTMENTS)
 12" DEEP ADJUSTABLE SHELF (4)
 SCBA BRACKET (2)

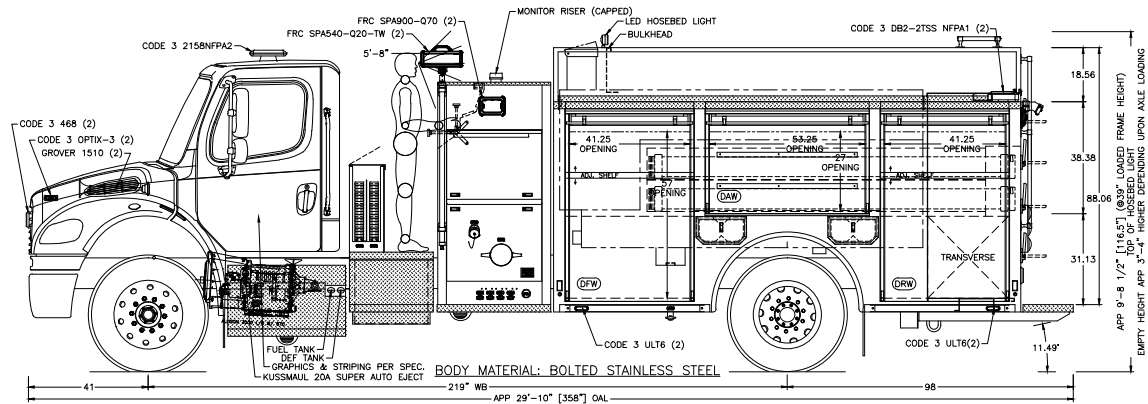
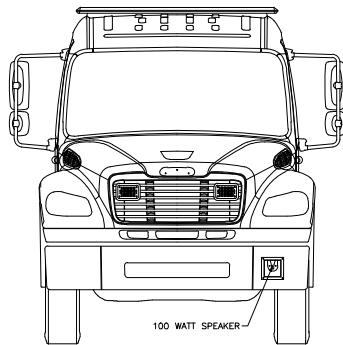
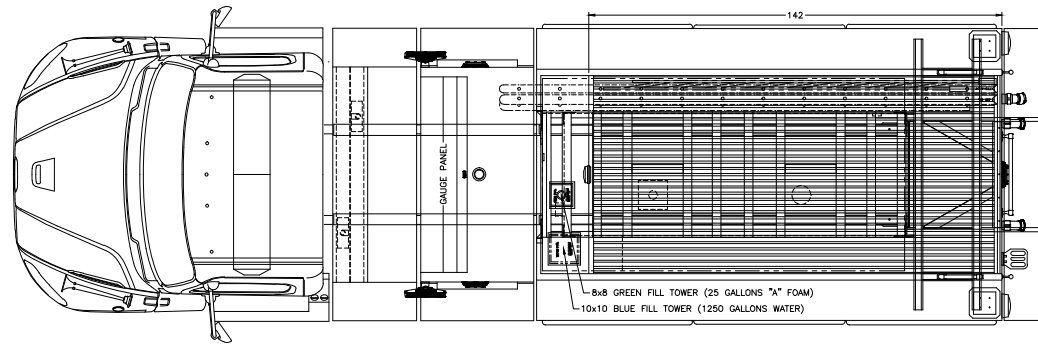

NOTE:
 DIMENSIONS SHOWN ARE APPROXIMATE AND ARE SUBJECT TO MINOR CHANGE AS MAY BE FOUND NECESSARY DURING CONSTRUCTION. MINOR DETAILS MAY NOT BE SHOWN. IF DISCREPANCIES EXIST BETWEEN THIS DRAWING AND THE WRITTEN SPECIFICATIONS PROVIDED BY TOYNE, THE WRITTEN SPECIFICATIONS SHALL PREVAIL.

ORIGINAL DRAWING	29FEB19	CHASSIS:	FRIEHLINER M2 106	SCALE:	1/66	SHEET:	A
		WB-CA-AF:	219"-153.4"-47" D17	CITY:	--		
		BODY MATL:	BOLTED STAINLESS STEEL	STATE:	--		
		PUMP:	HALE Q-FLO PLUS 1250	DLR:	TOY		
		TANK:	1250/25 UPF POLY-TANK III	CAD:	GROSSMAN		
		FOAM SYSTEM:	PRE PIPE	DATE:	29FEB19		
		GENERATOR:	N/A	FILE:	12418-A		

Toyne
Shift to take the call.

BREDA, IA 51436
 800-648-3358
 WWW.TOYNE.COM

DEMO 12418
 CUSTOM PUMPER